

SEKISUI

FOAM
INTERNATIONAL
Global Foam Solutions

Physically Cross-linked Polyolefin Foam

SOFTLON®

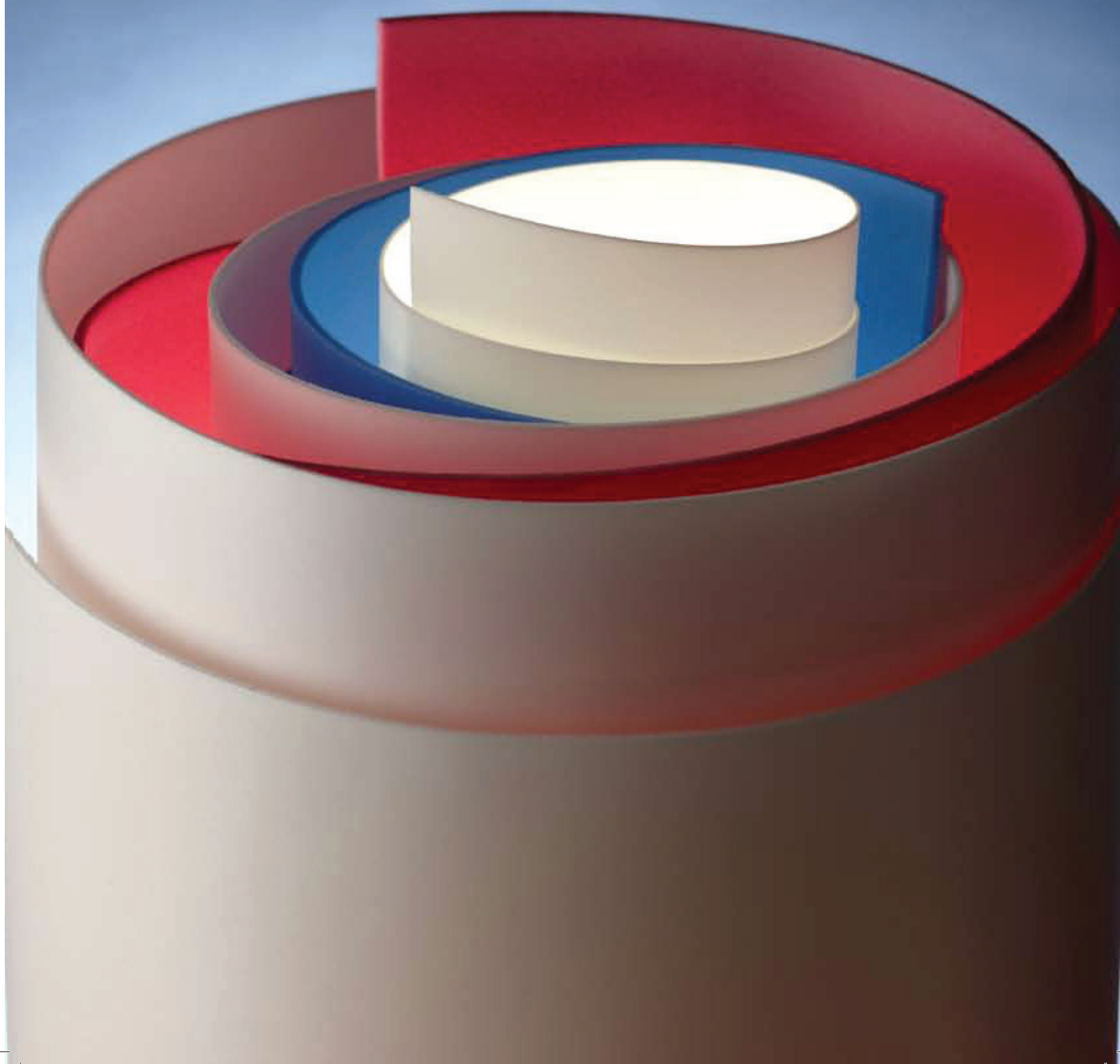

Foam : any number of light cellular solids made by creating bubbles of gas in a material



How SOFTLON is made

SOFTLON was created using new cross-linking following decades of Sekisui Chemical's propri

Extrusion

Extruding Polyolefin

Polyolefin resin is mixed with foaming agents and auxiliary materials, and formed through extrusion. Our high-precision extrusion technique is the basis for our products' fine thickness tolerance.

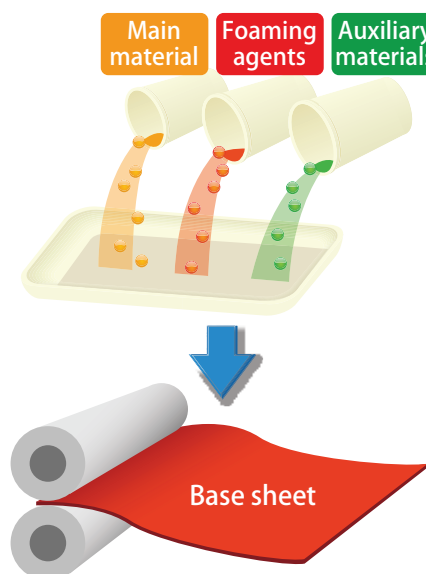

Cross-linking

Physically Cross-linking

Polyolefin is physically cross-linked with electron beams to cross-link the molecules. This electron irradiation technique is a unique technology in the field of applied industrial radiation, winning the Award of the Society of Polymer Science Japan.

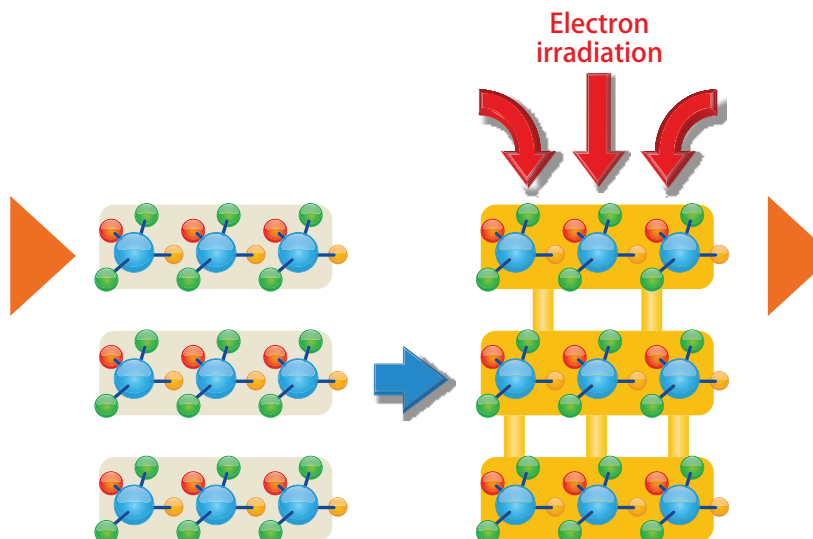

SEKISUI-SOFTLON is a material invented to
include air bubbles into polyolefin.

History of Sekisui's Foam Business

- 1964 SEKISUI-SOFTLON is developed at the R&D center
- 1967 Foam Promotion Division is established;
Production of SEKISUI-SOFTLON starts at Musashi Plant
- 1969 VOLTEK Inc. (now SEKISUI VOLTEK) is founded
- 1973 ALVEO AG (now SEKISUI ALVEO) is founded
- 1977 PILON PTY.LTD. (now SEKISUI PILON) is founded
- 1996 Thai Sekisui Foam Co., Ltd. is founded
- 2002 Capital participation in Shanghai Holy Co., Ltd. in China (51%)
- 2003 Capital participation in Young Bo Chemical Co., Ltd. in South Korea (51%)
- 2006 Construction of Langfang Plant of Young Bo Chemical is completed
- 2009 Sekisui Alveo acquires Polymer-Tec GmbH
- 2010 Shanghai Sekisui-Holy Plastics Co., Ltd. is liquidated
- 2010 Polymer-Tec changes its business name to SEKISUI ALVEO BS

making technology developed by Sekisui Chemical. The manufacturing technology was invented through proprietary research. Polyolefin foam is commercialised as SOFTLON through the following processes.

Foaming

Foaming

Foamed polyolefin expands from 5 to 40 times its original volume. The fine closed-cells are resistant to water and chemicals. This supports the stable, superior quality of SOFTLON.

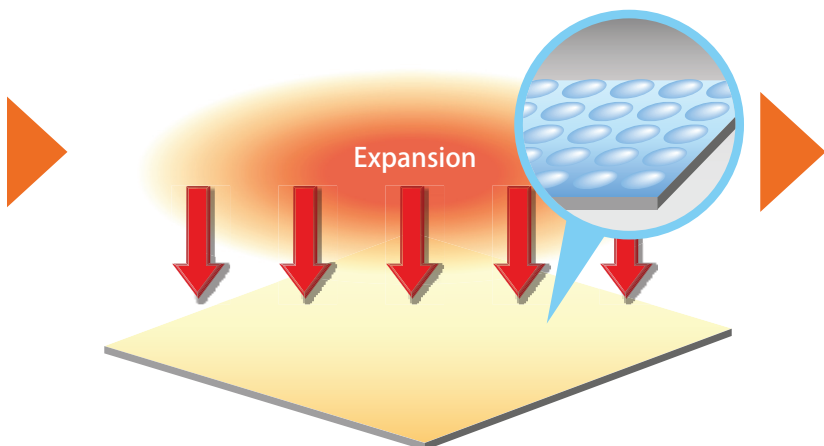

Winding

Winding into sheets

SOFTLON is a soft and continuous sheet-type product. SOFTLON allows for flexible fabrication, such as lamination and moulding.

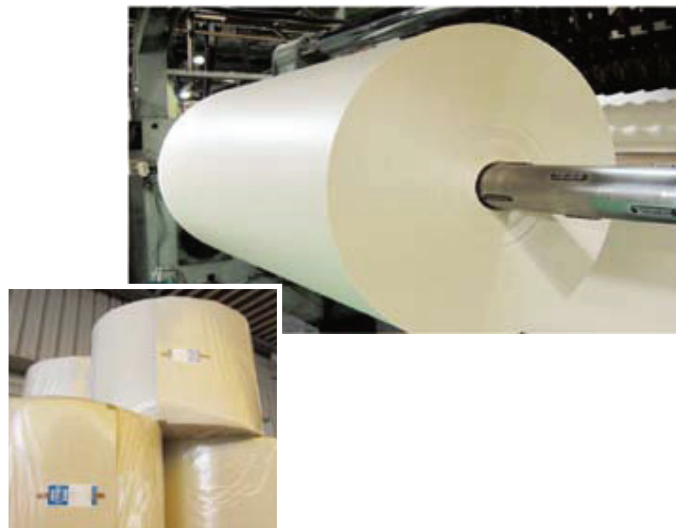

Product Concept of SOFTLON

1

Polyolefin Material

Chemical-resistant

Heat-moldable

SOFTLON features the properties exclusive to polyolefin materials. The chemical resistance of SOFTLON allows it to be used in products that require durability, such as residential insulation and automotive interiors. In addition, it can be easily fabricated due to its heat-mouldable property, ideal for lamination, vacuum forming and heat press moulding.

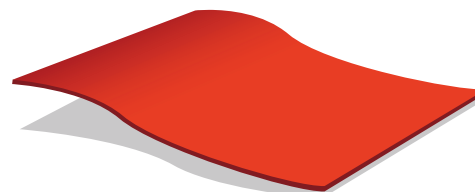

2

Cross-linking

Heat-resistant

Smooth surface

Sekisui Chemical's exclusive electron irradiation technique results in superior and discrete crosslinking. This gives SOFTLON a fine cell structure, better heat resistance and a smooth surface.

Electron irradiation

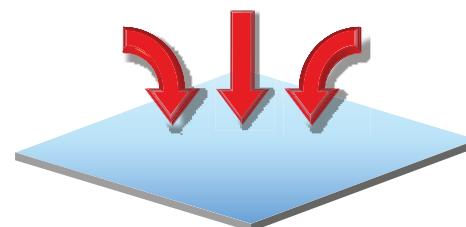

3

Foam Structure (Closed-cell)

Light weight

Flexible

Heat-insulating

SOFTLON consists of fine closed-cell foam. Lightweight and flexible properties are realised by foaming polyolefin to 5 to 40 times its original volume. As a characteristic of the closed-cell structure, SOFTLON is well suited for products that demand heat insulation and waterproofing.

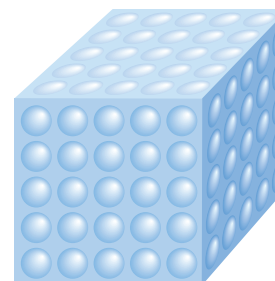

FAQs

About SOFTLON

Q1. Does SOFTLON use any environmentally harmful substances?

- A. The main raw material of SOFTLON is polyolefin resin, which is environmentally friendly. No prohibited materials are used in SOFTLON. Common uses of SOFTLON include cap seals, developmental toys, and parts for medical equipment.

Q2. What is the difference between closed cells and open cells?

- A. Unlike open cells, in a closed-cell structure, each air bubble is formed independent of each other. SOFTLON does not absorb water, has good thermal insulation properties and excellent cushioning characteristics.

Q3. What is the difference between electron cross-linking and chemical cross-linking?

- A. Products that are cross-linked using electron irradiation have a smooth, flat skin layer compared to chemically cross-linked products. Electron cross-linked products also have smaller, more even cell sizes.

Q4. Are there any other products made from raw materials other than polyolefin?

- A. Sekisui Chemical also offers a lineup of products that use special types of elastomer and/or rubber as the main material. These products perform special functions, such as vibration suppression and fluid seals.

SOFTLON can be fabricated into various shapes and sizes

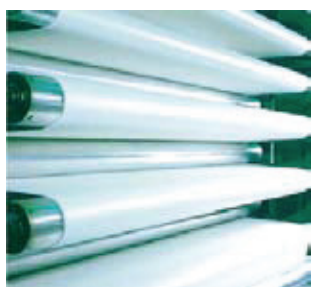

SEKISUI-SOFTLON

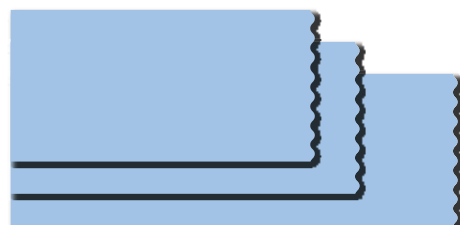
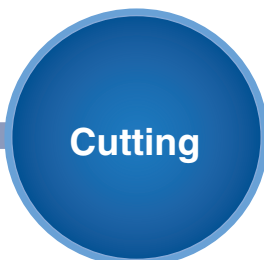

SOFTLON is easy to cut due to its softness.

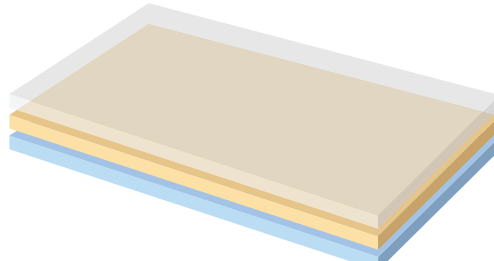

SOFTLON provides a thickness tolerance only available with Sekisui's exclusive foams. Bonding with films and nonwoven fabrics is also possible.

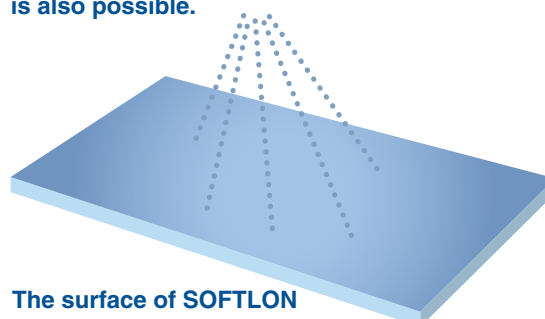

The surface of SOFTLON can be treated to allow easier application of adhesives.



SOFTLON can be skived from its standard thickness.

Other processing methods are also possible. Please consult our sales representative for more information.

FAQs

About Processing

Q1. What are the other possible processing techniques?

A. Slitting, texturing (embossing, engraving), routing and moulding are possible.

Q2. What is the suitable grade for thermoforming?

A. As moulding grades, there are SOFTLON SP, SOFTLON IF, and SOFTLON NF.

Q3. What thermoforming processes are possible?

A. Vacuum forming and heat press moulding are possible. Other heat moulding techniques include tubing, in which SOFTLON is moulded into a tube, and embossing on the surface.

Q4. What kinds of lamination are possible?

A. Any flexible material can be laminated to SOFTLON foam. For example: films, weaves, fabrics, foils or adhesives.

SOFTLON is offered in a product range suitable for various ind

Tape base / Seal material

Double-adhesive foam tape base,
Mobile phone gasket,
LCD television gasket, Cap seal, etc.

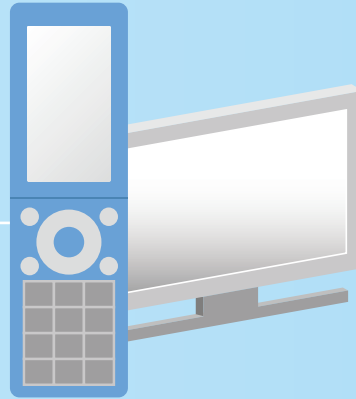

SOFTLON ES series

[Thin & High-Precision /
High-Strength & Flexible]

- SOFTLON IF
- SOFTLON ES

Automotive vehicle

Molded door surface lining,
Formed instrument panel lining,
Formed roof-back duct,
Rear light water seal, etc.

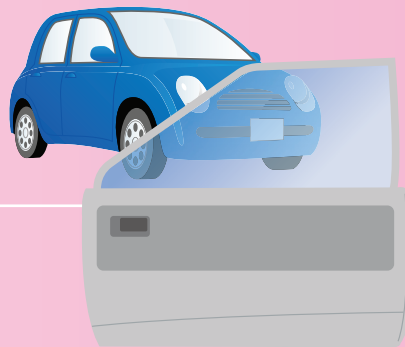

SOFTLON SP series

[Heat-Resistant, High-Strength /
For vacuum or
stamping forming]

- SOFTLON SP-VS
- SOFTLON SP-LPM

Heat insulation/ Industrial use

OEM , AC Manufacturing
Foam tapes

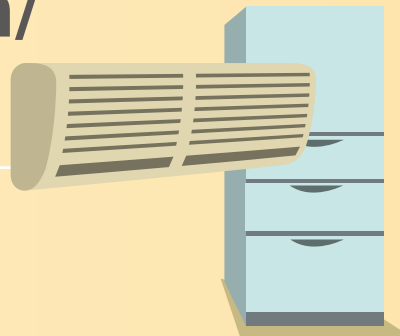

SOFTLON FRND/FR

[Fire retardant to UL94-HF1]

Housing / Construction materials

Heat insulator for metal roof,
Rooftop waterproof material,
Housing joint filler, Floor underlay,
Artificial turf underlay, etc.



Heat insulator for long metal folded- plate roof

[Roof lining]

- SOFTLON SK

Industries and applications

XLIM (X-Slim)

[Super-Thin IT seal]

Alveocel

[Special closed cell]

SOFTLON IF series

[Heat-Resistant & Flexible /
For deep drawing and
vacuum forming]

- SOFTLON IF

EXSEAL

[Special rubber water-
tight seal]

SOFTLON NF series

[Heat-Resistant & Rigid /
For deep drawing and
vacuum forming]

- SOFTLON NF

SOFTLON Z series

[Odorless, clean material /
High physical strength /
Stable]

- SOFTLON Z-LD
- SOFTLON Z-SD

SOFTLON S series

[General purpose
SOFTLON for
extensive application]

- SOFTLON S
- SOFTLON FR-ND

Artilon

[Heat insulator for rooftop insulation]

- Artilon

Artificial turf underlay

[Shockproof & Durable]

- Alveosport
- Softlon Playsafe

SOFTLON Ezi-Lay

[Floor underlay]

SOFTLON can be used in many and varying applications

For tape bases & seals

Use 1

Double-adhesive foam tape base

SOFTLON S

SOFTLON S is a new type of foam that realises both thinness and flexibility. Used as tape base, this series can contribute to the creation of thinner, higher-performance products and new fields.

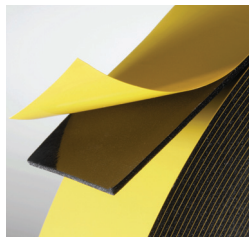

Product name	Specifications
SOFTLON S	Thickness: 1 mm - 1.5 mm

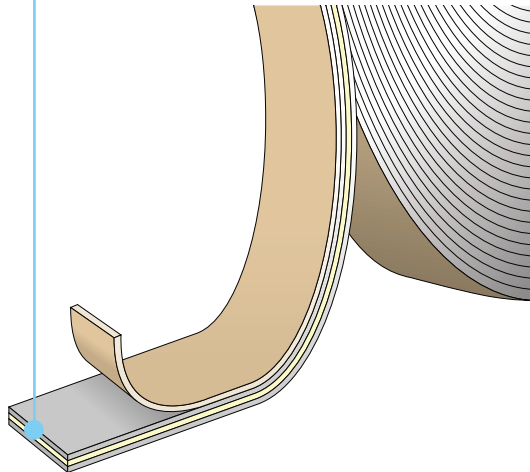

Use 2

Cap seal

SOFTLON S, ALVEOCEL

SOFTLON S (5/10 Foam) complies with the standards provided in the Voluntary Regulations on Synthetic Resin Food Container and Packaging issued by Japan Hygienic Olefin and Styrene Plastics Association.



Product name	Specifications
SOFTLON S	Thickness: 1.5 mm - 2mm
ALVEOCEL	

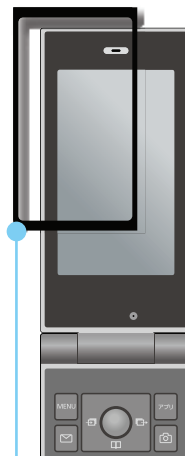

Use 3

Medical Pads

SOFTLON ES

SOFTLON ES lineup is a polyethylene/EVA copolymer foam that features excellent flexibility. This allows medical pads to fit perfectly on any uneven surface.



Product name	Specifications
SOFTLON ES ES 1501.5	1.5 mm x 1000 mm

Use 4

IT seal

XLIM (X-slim)

This high-performance foam enables household appliances, including mobile phones, digital cameras, video cameras, and TV, to be made more compact as well as ensuring that the products are both water and dustproof.



Product name	Product name
XLIM	Thickness: 0.1~2 mm

For automotive vehicles

Use
1

Formed door surface lining

SOFTLON SP

This polypropylene-based foam has superior heat resistance and is customised to provide great vacuum and stamp formability.



Product name	Specifications
SOFTLON SP-VS	Thickness: 1 mm - 3 mm

Use
2

Formed roof-back duct

SOFTLON-PLUS (SOFTLON + Sheet)

SOFTLON-PLUS is significantly lighter when compared to blow-moulded products. It also features good heat insulation and formability. Please contact us for the foam's seat combination and other specifications.

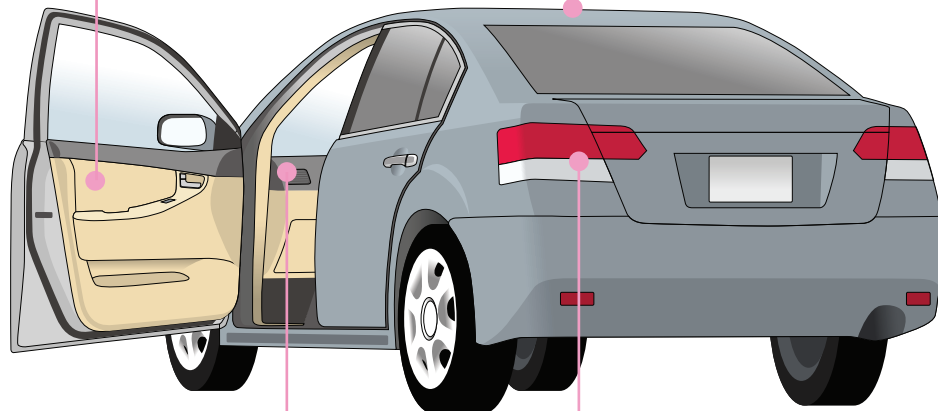

Product name	Specifications
SOFTLON SP-FR #2505+PP	Thickness: 5 mm

Use
3

Formed instrument panel surface lining

SOFTLON SP

SOFTLON SP offers grades particularly suitable for moulding edge parts for instrument panels into sharp contours.



Product name	Specifications
SOFTLON SP-VS #15025	Thickness: 2.5 mm

Use
4

Rear light water seal

EXSEAL

The fusion of Sekisui-exclusive foam technology and adhesive control technology creates this watertight seal that provides both low rebound and the ability to stop water.



Product name	Specifications
EXSEAL	Thickness: 3 mm, 4 mm, 5mm

SOFTLON has numerous applications and uses

For heat insulation & industrial use

Use 1 Heat insulator in air conditioning system

SOFTLON FR-ND

SOFTLON FR-ND is flame retardant without using PBDE or PBB, materials prohibited by the Restriction of Hazardous Substances (RoHS) Directives.



Product name	Specifications
SOFTLON FR-ND	Thickness: 2 mm - 10 mm

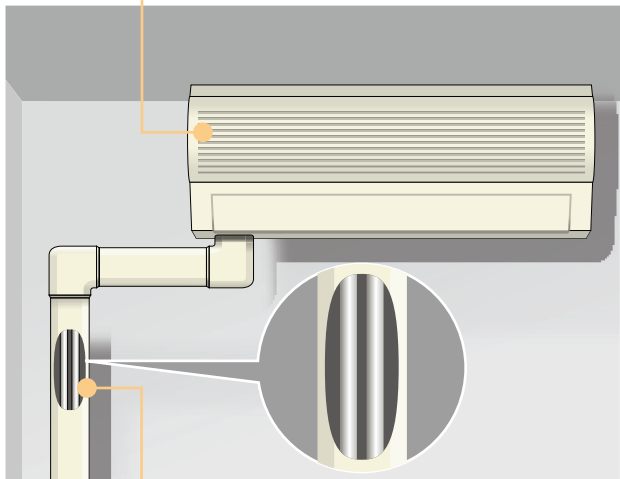

Use 2 Heat insulator coating resin tubes

SOFTLON PE laminated product

This heat-insulated tube is produced by heat-laminating SOFTLON with PE films (blue and red) and subsequent embossing and tubing. Weatherproofing is also available. Please contact us for specifications.

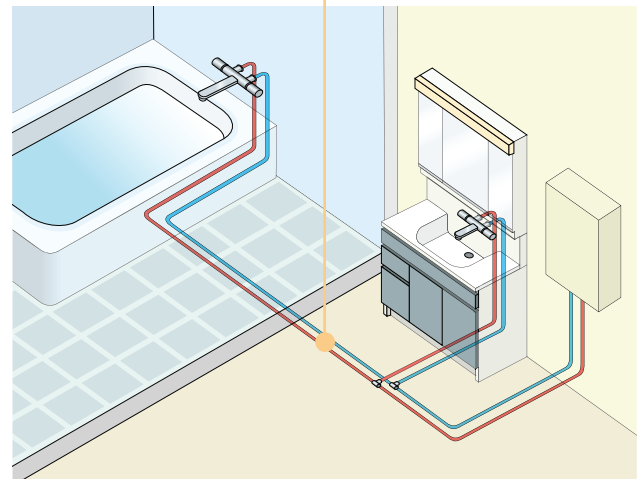

Use 3 Heat insulated tubes for air conditioner units

SOFTLON NF

SOFTLON NF offers good heat formability. It can be made into tubes or deep-drawn through vacuum forming. Designs and patterns can be clearly embossed. Superb heat-resistance and mechanical strength.



Product name	Specifications
SOFTLON NF	Thickness: 2 mm - 10 mm Width: 1,000 mm Length: 200 m

Use 4 Anti-static buffer

SOFTLON Z

SOFTLON Z is produced through physical foaming by nitrogen impregnation. LD30SD is our customers' preferred conductive buffer for use in electronic parts where static electricity and outgassing need to be avoided.

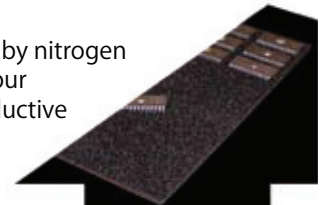

Product name	Specifications
SOFTLON Z-LD30SD	Thickness: 35 mm Width: 1,000 mm Length: 1,900 mm

For housing & construction materials

Use
1

Heat insulation for metal roofs

SOFTLON FR-ND

This heat insulator for metal roofs is excellent at preventing condensation. In addition to its good basic heat insulation and condensation prevention performance, it is also outstanding in terms of its processability and workability, such as thermal fusion bonding (heat adhesion) and roll forming.

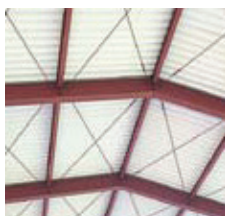

Product name	Specifications
SOFTLON FR-ND	Thickness: 4 mm - 6 mm Width: 880 mm

Use
2

Artificial turf underlay

Alveo Sports Layer

Our artificial turf underlay offers stable performance in all weather conditions. Alveo Sports Layer adopts a closed-cell structure, which makes it highly shock-absorbent and durable, as well as preventing it from absorbing water. Special processing also adds to its workability. Alveo Sports Layer has been used in constructing soccer grounds and is highly recommended.

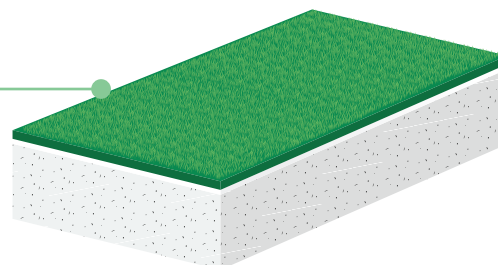
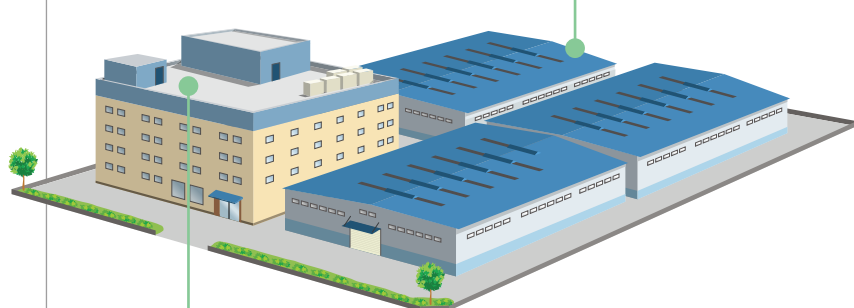

Product name	Specifications
Alveo Sports Layer	Thickness: 12 mm Width: 2,000 mm Length: 75 m

Use
3

Heat insulation for rooftop

Artilon

Not only is Artilon great as heat insulator, this chemically cross-linked product also accommodates the diversity of rooftop waterproofing techniques, higher functionality, and power-saving construction.



Product name	Specifications
Artilon	Thickness: 10 mm to 50 mm

Use
4

Floor Underlay

SOFTLON Ezi-Lay

Softlon Ezi-Lay is an outstanding timber floor underlay solution. Key functions include:

- Absorbs unevenness in the subfloor.
- Provides barrier to water vapour.
- Reduces floor drum (echo) sound.
- Provides impact sound insulation.
- Improves timber floor impact resistance

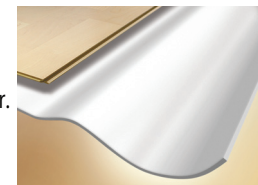

Product name	Specifications
SOFTLON Ezi-Lay	Thickness: 2 mm Width: 1000 mm Length: 20 m, 50 m

Key Properties of SEKISUI-SOFTLON®

Heat insulation

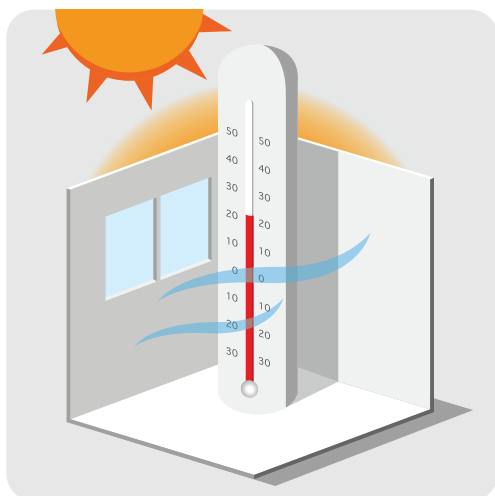

The layers of air provided by the closed cells that shape SOFTLON provide low thermal conduction and excellent heat insulation. It is an energy-saving material optimal for purposes that require heat or cold to be retained. The water repellent quality also prevents the heat insulation performance from deteriorating due to water absorption.

■ Comparison of the heat insulation property of SOFTLON S and other materials

Material	Density (kg/m ³)	Thermal conduction (W/mK)
SOFTLON FRND/FR	25	0.032
Soft urethane foam	25	0.0372
Rigid urethane foam	25~35	0.0342~0.0582
Polystyrene foam	16~30	0.0302~0.0440
Glass wool	10	0.0395
PVC Nitrile	65~80	0.038

*Comparison conducted by Sekisui

*Physical property values are representative values and cannot be used as standards.

Formability

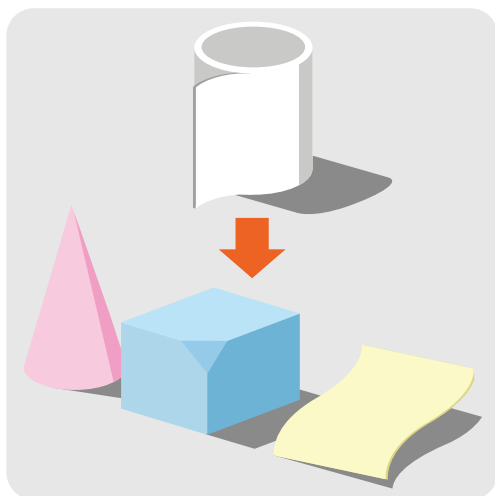

SOFTLON is equipped with superior mechanical characteristics, including tensile strength, elongation, and tear strength, which are properties of the electron cross-linked polyolefin foam. The heat formability allows SOFTLON to be deep-drawn using vacuum forming. Designs and patterns can also be clearly embossed.

■ Relation of tensile strength and apparent density

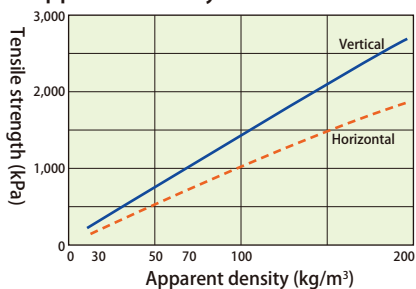

■ Relation of elongation and apparent density

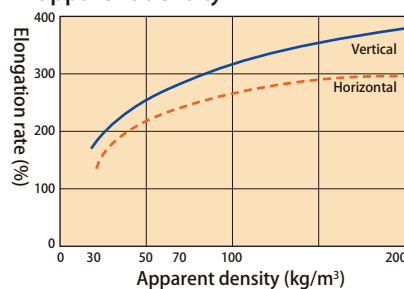

*Physical property values are representative values and cannot be used as standards.

■ RA% (processability) by grade

SOFTLON NF	#3003	0.7
SOFTLON SP	#1502	1.0
	#3003	0.8
SOFTLON IF	#1505	1.0
	#30025	0.9
SOFTLON S	#3003	0.6

*Formability is determined by the maximum RA% (shown above).

Grades with an RA% of over 0.8 have especially good thermal processability.

Heat resistance / Flame-retardant property



SOFTLON's typical operating temperature is -80°C up to 120°C depending on grade.

Dimensional change under heat (22 hours under 70°C) (by grade)

Grade	Dimension change rate*	Temperature (22h)
SOFTLON S #0503	-0.3%	70°C
SOFTLON S #3003	-1.1%	70°C
SOFTLON NF #3003	-3.8%	100°C
SOFTLON SP #2502	-1.7%	120°C
SOFTLON Z NB50	-1.3%	200°C

*Measuring method based on JIS K6767; property values are representative values and cannot be used as standards.

*Dimension change rate is the average of Machine and Cross Direction.

Shock absorption



SOFTLON offers excellent shock-absorbent properties. SOFTLON is flexible and exhibits superior compression properties.

Comparison of shock absorption of SOFTLON S and other material

Measurement item	Unit	SOFTLON S (Polyethylene foam)	Soft urethane foam (ether)	Soft PVC foam	Polystyrene foam
Cell structure		Closed	Open	Closed	Closed
Thickness	mm	3.00	9.84	4.82	5.20
Apparent density	kg/m ³	33 (0.033g/cm ³)	17 (0.017g/cm ³)	140 (0.14g/cm ³)	32 (0.032g/cm ³)
Tensile strength	Vertical	kPa 420 (4.3kgf/cm ²)	90 (0.94kgf/cm ²)	980 (10.0kgf/cm ²)	-
	Horizontal	" 290 (3.0kgf/cm ²)	100 (1.04kgf/cm ²)		-
Elongation	Vertical	% 204	179	111.5	-
	Horizontal	" 165	212		-
Compressive strength	25%	kPa 34 (0.35kgf/cm ²)	2.5 (0.026kgf/cm ²)	64 (0.65kgf/cm ²)	240 (2.46kgf/cm ²)
	50%	" 98 (1.00kgf/cm ²)	3.2 (0.033kgf/cm ²)	145 (1.48kgf/cm ²)	307 (3.13kgf/cm ²)
	75%	" 320 (3.25kgf/cm ²)	5.7 (0.058kgf/cm ²)	-	542 (5.53kgf/cm ²)
Compression set	%	6.5	1.5	3.0	21.5

*Comparison conducted by Sekisui

*Physical property values are representative values and cannot be used as standards.

List of Functions by Grade

	Basic performance (Common functions)					Additional performance				
	Heat insulation	Shock absorption	Water resistance	Moisture resistance	Chemical resistance	Heat resistance	Fire-retardant property	Form-ability	Surface strength	Water-tightness
SOFTLON S	○	○	○	○	○	Standard				
SOFTLON FR-ND	○	○	○	○	○		○			
SOFTLON IF	○	○	○	○	○			○	○	
SOFTLON NF	○	○	○	○	○	○		○	○	
SOFTLON SP	○	○	○	○	○	○		○	○	
ARTILON	○	○	○	○	○				○	
SOFTLON SK	○	○	○	○	○					
SOFTLON Z	○	○	○	○	○	○				
XLIM (X-slim)	○	○	○	○	○					
SOFTLON ES	○	○	○	○	○				○	
EXSEAL	○	○	○	○	○					○

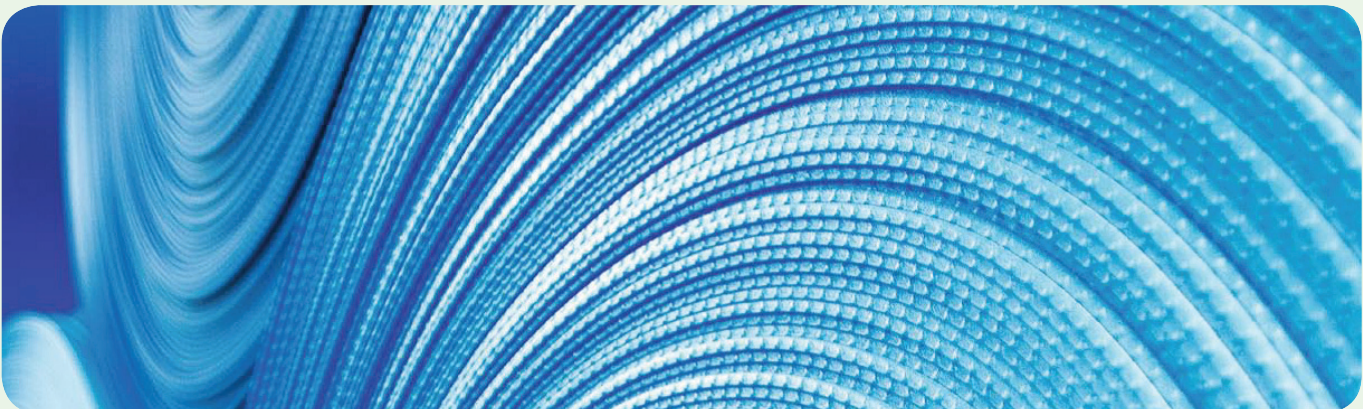

[Typical] Physical Properties of SOFTLON-S



Property	Unit	# 0503	# 1003	# 1503	# 2003	# 3003	# 4003
Cell structure		Closed	Closed	Closed	Closed	Closed	Closed
Average diameter of cell	mm	0.26	0.27	0.28	0.30	0.30	0.32
Apparent density	g/cm ³	0.20	0.10	0.066	0.05	0.033	0.025
Thickness^(Note 1)	mm	3	3	3	3	3	3
Tensile strength	kPa (Vertical)	2,570	1,290	950	560	420	310
	kPa (Horizontal)	1,790	1,000	510	400	290	220
Elongation	% (Vertical)	380	328	280	220	204	161
	% (Horizontal)	300	265	175	170	165	141
Tear strength	kPa (Vertical)	122.5	61.7	41.2	31.4	23.5	19.6
	kPa (Horizontal)	101.9	51.0	30.4	20.6	14.7	12.7
Compressive hardness	kPa	15.7	8.3	5.6	5.0	3.1	2.6
Compressive strength	kPa (25%)	323	63	59	53	33	29
	kPa (50%)	559	155	143	128	98	83
	kPa (75%)	1,735	502	441	343	320	246
Compression set	%	3.5	4.0	4.5	5.1	6.5	7.5
Repeat Compression set	%	3.0	3.4	4.0	4.5	5.3	5.9
Thermal Conductivity	W/mK	—	—	—	—	0.0345	0.0321
Dimensional change under heat (22 hours under 70 degrees C)	% (Vertical)	-0.54	-0.83	-1.03	-1.43	-1.45	-1.50
	% (Horizontal)	-0.10	-0.20	-0.30	-0.40	-0.75	-0.90
Water absorption	mg/cm ³	0.02	0.03	0.04	0.05	0.07	0.09

(Measuring method: JIS K 6767)

<Note 1> Thickness: Foams are flexible in general. During measurement, as the sample foam changes its thickness depending on the compression, a dial gauge with 0.01 mm graduation was used with a sample area of 10 cm² and sample pressure 2g/cm².

<Note 2> Physical property values are representative values and cannot be used as standards.

Foam production bases

Sekisui Chemical is the world's largest & leading manufacturer of cross-linked polyolefin foam and operates **11** plants worldwide. All operating under ISO quality systems.

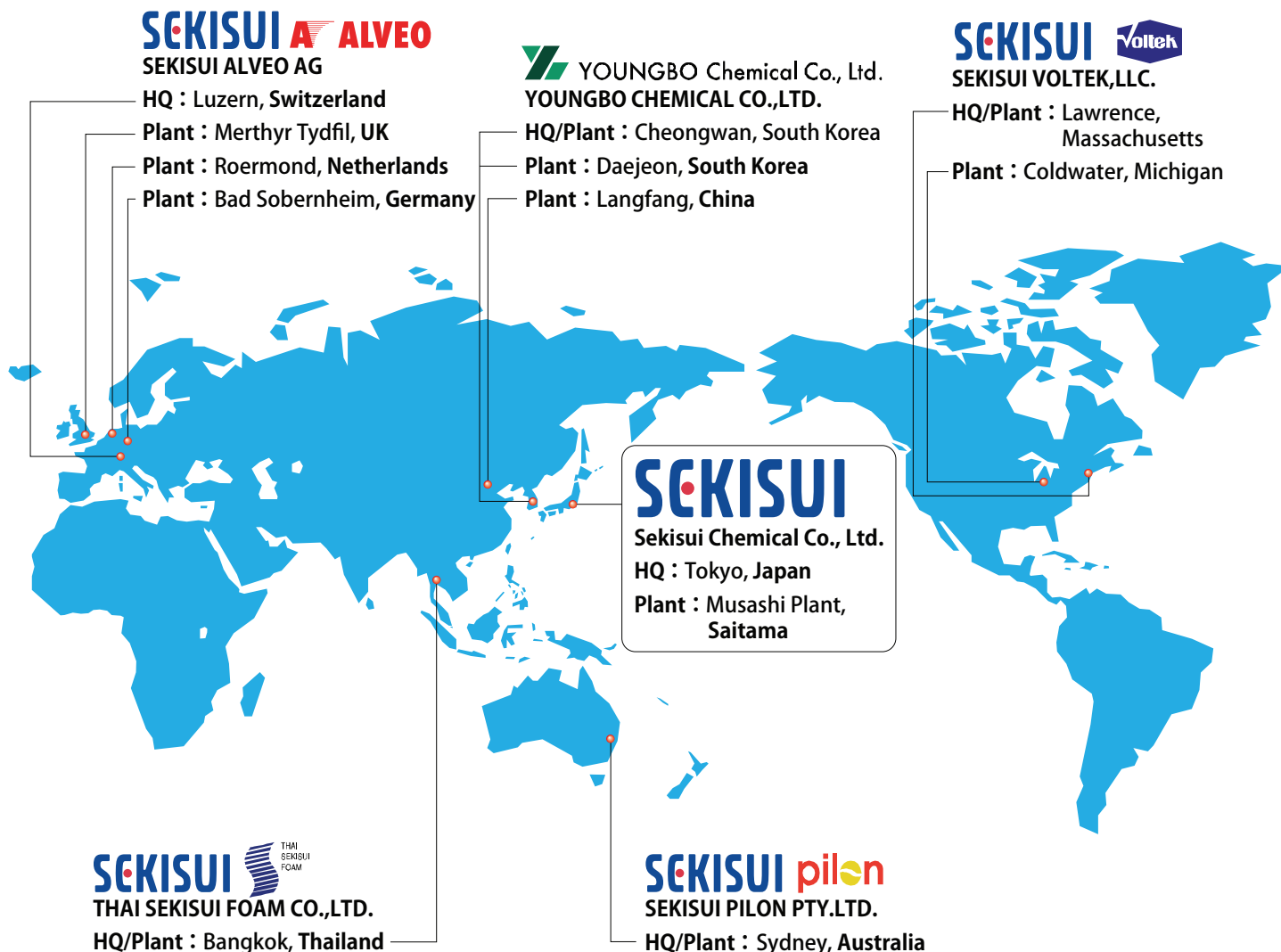

SEKISUI

FOAM
INTERNATIONAL
Global Foam Solutions

Sekisui Pilon Pty Ltd
1-5 Parraweena Rd,
Taren Point NSW 2229 Australia
Tel: +61 2 9525 9880
Fax: +61 2 9525 8004
www.sekisuipton.com.au

Thai Sekisui Foam
Amata Nakorn Industrial Estate,
700/329 Moo 6, Tumbol Donhua-Ioh,
Amphur Muang Chonburi 20000 Thailand
Tel: +66 3821 3219 ~ 26
Fax: +66 3821 3281
www.thaisekisui.co.th

*Not all products available in all markets.
*Specifications are subject to change without notice due to modifications.
© Copyright 2011 Sekisui Chemical Co. Ltd